

**ICC Evaluation Service, Inc.**  
[www.icc-es.org](http://www.icc-es.org)

**Business/Regional Office** ■ 5360 Workman Mill Road, Whittier, California 90601 ■ (562) 699-0543  
**Regional Office** ■ 900 Montclair Road, Suite A, Birmingham, Alabama 35213 ■ (205) 599-9800  
**Regional Office** ■ 4051 West Flossmoor Road, Country Club Hills, Illinois 60478 ■ (708) 799-2305

**DIVISION: 06—WOOD AND PLASTIC**  
**Section: 06120—Sheathing**

**DIVISION: 07—THERMAL AND MOISTURE PROTECTION**  
**Section: 07210—Building Insulation**

**DIVISION: 09—FINISHES**  
**Section: 09830—Acoustical Barriers**

**REPORT HOLDER:**

**HOMASOTE COMPANY**  
**POST OFFICE BOX 7240**  
**WEST TRENTON, NEW JERSEY 08628**  
**(800) 257-9491**  
[www.homasote.com](http://www.homasote.com)  
[sales@homasote.com](mailto:sales@homasote.com)

**EVALUATION SUBJECT:**

**HOMASOTE INSULATING BOARDS: HOMASOTE 440 SOUND BARRIER®; COMFORT BASE®; HOMEX 300®; NOVA CORK®; BURLAP PANEL; 440 PINacle™ BOARD**

## 1.0 EVALUATION SCOPE

**Compliance with the following codes:**

- 2003 *International Building Code*® (IBC)
- 2003 *International Residential Code*® (IRC)

**Properties evaluated:**

- Structural
- Fire resistance
- Surface-burning characteristics
- Sound transmission

## 2.0 USES

Homasote insulating boards are used for interior and protected exterior wall finish materials, as sound insulation, expansion joint material and wall sheathing. See Section 3.0 for a description of the different boards and their applications. The Homasote 440 Sound Barrier is also recognized for use as structural sheathing and in fire-resistance-rated assemblies.

## 3.0 DESCRIPTION

Homasote is a fiberboard complying with Section 2303.1.5 of the IBC and Table R602.3(1), Footnote h, of the IRC. It is made of approximately 98 percent post-consumer wastepaper, wood fiber and flame-retardant chemicals, 2 percent paraffin wax and less than 0.1 percent copper metaborate. All products are free of asbestos, formaldehydes, ureas or phenolic additives.

### 3.1 Homasote 440 Sound Barrier:

Homasote 440 Sound Barrier is a lightweight sound-deadening material and sheathing, weighing 26 to 28 pounds per cubic foot (416.5 to 448.5 kg/m<sup>3</sup>). When used as sound-deadening material, the boards are installed as flooring underlayment on top of wood subflooring and concrete, and between gypsum board and studs in walls. When used as structural sheathing, the boards are installed as described in Section 4.2. Homasote 440 has a flame-spread index of not greater than 200 and a smoke-developed index of not greater than 450. The standard sizes of the boards are as follows:

1/2-inch thickness	4 feet by 4 feet (1219 mm by 1219 mm)
	4 feet by 8 feet (1219 mm by 2438 mm)
	4 feet by 10 feet (1219 mm by 3048 mm)
5/8-inch thickness	4 feet by 8 feet (1219 mm by 2438 mm)
	4 feet by 10 feet (1219 mm by 3048 mm)
3/4-inch thickness	4 feet by 8 feet (1219 mm by 2438 mm)

### 3.2 Comfort Base:

Comfort Base is similar to 440 Sound Barrier, weighing 26 to 28 pounds per cubic foot (416.5 to 448.5 kg/m<sup>3</sup>). It is designed to be used as an underlayment over concrete surfaces and allows concrete to release moisture without causing panels to curl or bow. Comfort Base fiberboard has a flame-spread index of not greater than 200 and a smoke-developed index of not greater than 450.

### 3.3 Homex 300:

Homex 300 is made from approximately 98 percent post-consumer wastepaper with 2 percent paraffin wax and less than 0.1 percent copper metaborate. The panels weigh 26 to 28 pounds per cubic foot (416.5 to 448.5 kg/m<sup>3</sup>). These panels are used as isolation/expansion joint material in areas where masonry or concrete walls meet outside aprons, walks, patios or steps. Other uses include light-duty concrete forming in such applications as walkways, patios, pool aprons, and driveways. Homex 300 is available in strips 1/2 inch (12.7 mm) thick by 3, 3 1/2 and 4 inches (76, 89 and 102 mm) wide by 8 or 10 feet (2438 or 3048 mm) long. It is also available in 4-foot-by-10-foot-by-1/2-inch-thick (1219 mm by 3048 mm by 12.7 mm) panels for custom applications.

### 3.4 Nova Cork:

Nova Cork is a factory-prefinished interior paneling composed of natural virgin cork laminated to one side or both sides of Homasote 440 fiberboard. The panels are available in 4-foot-by-8-foot and 4-foot-by-10-foot (1219 mm by 2439 mm and 1219 mm by 3048 mm) or smaller, cut-to-size dimensions and weigh 24 to 26 pounds per cubic foot (384.5 to 416.5 kg/m<sup>3</sup>). Nova Cork has a flame-spread index of not greater than 75 and a smoke-developed index of not greater than 450.

### 3.5 Burlap Panel:

Burlap Panel is a factory-prefinished interior paneling composed of an all-natural heavyweight jute fabric laminated

to a Homasote 440 fiberboard. The panels come in a  $\frac{1}{2}$ -inch (12.7 mm) thickness and a 4-foot (1219 mm) width, and in lengths of 8 feet (2438 mm) and 10 feet (3048 mm). They weigh 24 to 26 pounds per cubic foot (384.5 to 416.5 kg/m<sup>3</sup>). Burlap Panel has a flame-spread index of not greater than 200 and a smoke-developed index of not greater than 450.

### 3.6 440 PINacle™ Board:

The 440 PINacle™ Board is used for interior and protected exterior use. The boards are finely sanded, with a suede-like feel to the touch. The panels come in a  $\frac{1}{2}$ -inch (12.7 mm) thickness and a 4-foot (1219 mm) width, and in lengths of 8 feet (2438 mm) and 10 feet (3048 mm). They weigh 26 to 28 pounds per cubic foot (416.5 to 448.5 kg/m<sup>3</sup>). The 440 PINacle™ Board has a flame-spread index of not greater than 75 and a smoke-developed index of not greater than 450. This product is the prefinished version of the 440 Sound Barrier®.

## 4.0 DESIGN AND INSTALLATION

### 4.1 General:

The manufacturer's installation instructions as to supporting, nailing, spacing, and joints shall be strictly adhered to and copies of these instructions shall be available on the jobsite during construction.

### 4.2 Homasote 440 Sound Barrier:

When used as a structural sheathing (shear wall) (allow  $\frac{3}{16}$  inch [4.76 mm] separation between panel edges), sheets shall be nailed to conventional wood framing on 16-inch (406 mm) centers with No. 11 gage galvanized roofing nails  $1\frac{1}{2}$  inches (38.1 mm) long, with  $\frac{7}{16}$ -inch-diameter (11.1 mm) heads, spaced at 3 inches (76.2 mm) on center at edges and 6 inches (152.4 mm) on center at intermediate supports. The wall shall be constructed as described in Sections 2306.4.4 and 2308.9.3 and Table 2308.9.3(4) of the IBC, or Section R602.10 and Table R602.3(1) of the IRC.

Homasote 440 Sound Barrier is also used as a sound-deadening board in walls and floor/ceiling assemblies. When used as a sound barrier in floor and ceiling assemblies, Homasote 440 Sound Barrier has a sound transmission classification as indicated in Table 1 of this report.

### 4.3 Fire-resistance Rating:

**4.3.1 Fire-resistance Wall Rating:** Homasote 440 Sound Barrier is permitted to be used in a one-hour fire-resistance-rated nonload-bearing wall assembly when constructed as indicated in Figure 2.

**4.3.2 Fire-resistance Floor and Ceiling Rating:** Homasote 440 Sound Barrier is permitted to be used in a one-and-a-half-hour fire-resistance-rated floor ceiling assembly when constructed as indicated in Figure 1.

## 5.0 CONDITIONS OF USE

The Homasote Boards described in this report comply with, or are suitable alternatives to what is specified in, those codes listed in Section 1.0 of this report, subject to the following conditions:

- 5.1 Homasote insulation board is not to be used as a plaster base.
- 5.2 All products shall be installed in a dry condition.
- 5.3 Homasote 440 Sound Barrier shall not be used to resist seismic forces in structures in Seismic Design Category D, E or F.

## 6.0 EVIDENCE SUBMITTED

- 6.1 Reports of testing in accordance with ASTM E 84.
- 6.2 Reports of acoustical testing in accordance with ASTM E 90 and ASTM E 492.
- 6.3 Reports of testing in accordance with ASTM C 209, as required by ASTM C 208.
- 6.4 Reports of testing in accordance with UL-263 (ASTM E 119).
- 6.5 A quality control manual.
- 6.6 Manufacturer's installation instructions.

## 7.0 IDENTIFICATION

Homasote products covered by this report, or their packaging, shall be marked for identification with the name of the manufacturer (Homasote), the product name, the statement "Complies with ASTM C 208, Type, and Grade," and the evaluation report number (ESR-1374).

TABLE 1—ACOUSTICAL RATINGS OF HOMASOTE® FLOOR-CEILING ASSEMBLIES

	STC 51 - IIC 75	STC 52 - IIC 50	STC 52 - IIC 77	STC 54 - IIC 51	STC 52 - IIC 51	STC 50 - IIC 71	STC 55 - IIC 82	STC 53 - IIC 55	STC 51 - IIC 72	STC 52 - IIC 60	STC 44 - IIC 23	STC 52 - IIC 74	STC 53 - IIC 42	STC 51 - IIC 53
Carpet & Pad	x		x			x	x		x			x		
Vinyl		x						x						
Tile													x	
3/8" Wood Laminate Floor					x					x				
3/4" Hardwood Flooring				x										x
1/2" ComfortBase™ *										x				x
1/2" 440 Sound Barrier®	x	x		x	x	x	x	x	x			x	x	
3/4" 440 Sound Barrier®			x											
1/4" Plywood		x						x						
5/8" CDX Plywood						x						x		
3/4" Wood Subfloor	x	x	x	x	x		x	x	x				x	x
TJI® Pro 250 Joist	x	x	x											
TJI® Pro 150 Joist						x						x		
16" Open Web Joist					x		x		x				x	
18" Open Web Joist				x				x						
3 1/2" Fiberglass Insulation										x				
4" Fiberglass Insulation												x		
6 1/4" Fiberglass Insulation	x	x	x											
6 3/4" Fiberglass Insulation				x			x	x						
Resilient Channels	x	x	x	x	x	x	x	x	x	x		x	x	
2 Layers 1/2" Type C Gypsum						x						x		
5/8" Type X Gypsum	x	x	x	x	x		x	x	x	x			x	
4" Concrete Slab											x			
6" Concrete Slab										x				
8" Concrete Slab														x
Drop Ceiling										x				

\*ComfortBase is used in applications over concrete.

**FIGURE 1**  
 UL Design No. L547  
 Unrestrained Assembly Rating—1½ Hour  
 Finish Rating—60 Minute

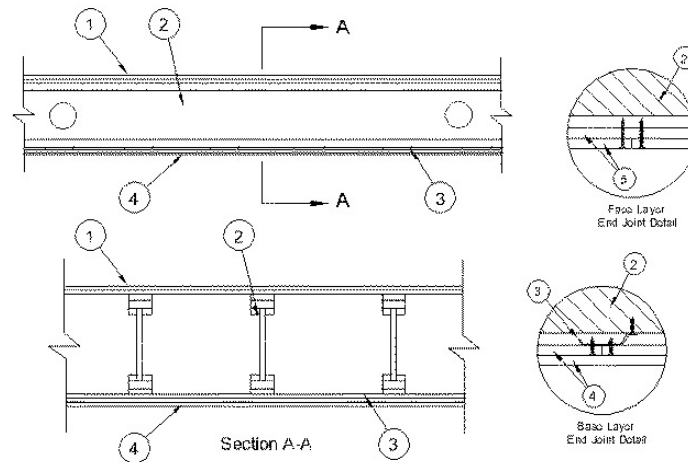

1. **Flooring System**—The flooring system shall consist of one of the following:

**Subflooring**—Min 5/8-inch-thick plywood wood structural panels, min grade "Underlayment" or "Single-Floor". Face grain of plywood to be perpendicular to trusses with joints staggered.

**Finish Floor - Mineral and Fiber Board\***—Min 1/2-inch-thick, supplied in sizes ranging from 3 feet by 4 feet to 8 feet by 12 feet. All joints to be staggered a min of 12 inches with adjacent sub-floor joints.

**HOMASOTE CO**—Type 440-32 Mineral and Fiber Board

2. **Structural Wood Members**—Min 9½ inches deep "I" shaped wood joists spaced max 19.2 in OC, and blocked at the ends using 2 inch by 10 inch wood members. Min joists bearing on bearing plates shall be 5½ inch Joists secured to the bearing plates with two 8d or 10d nails at each end. Circular holes may be cut in the web of joists in accordance with the manufacturer's published installation instructions.

**TRUS JOIST WEYERHAEUSER BUSINESS**—TJI® 110, TJI® 210, TJI® 230, TJI® 360, TJI® 560, TJI®/L45, TJI®/L65, TJI®/L90, TJI®/H90, TJI®/HD90, TJI®/HS90, TJI® 100C, TJI® 300C, TJI® 400C.

2A. **Alternate Structural Wood Members\***—Min 14 inch deep wood and steel trusses spaced a max of 19.2 inches OC. Min bearing and nailing or bolting to bearing plates (through steel bearing clips) shall be in accordance with the manufacturer's installation instructions.

**TRUS JOIST WEYERHAEUSER BUSINESS**—Types TJH, TJL(X), TJM, TJS, TJW, TJL.

3. **Resilient Channels**—Resilient channels, 3/8 inch deep by 23/8 inch wide at the base and 13/8 inch wide at the face, formed from 0.020-inch-thick galv steel, spaced 16 inches OC perpendicular to joists. Channels secured to each truss with 15/8 inch long Type S bugle head steel screws. As an alternate to the resilient channels, **Steel Framing Members\*** (Item 3A) may be used.

3A. **Steel Framing Members - (Not Shown)\***—As an alternate to Item 3, furring channels and **Steel Framing Members\*** as described below:

- Furring Channels**—Formed of No. 25 MSG galv steel, 23/8 inches wide by 7/8 inches deep, spaced 24 inches OC perpendicular to joists. Channels secured to trusses as described in Item b. Ends of adjoining channels overlapped 6 inches and tied together with a double strand of No. 18 SWG galvanized steel wire near each end of overlap.
- Steel Framing Members\***—Used to attach furring channels (Item a) to joists (Item 2). Clips spaced 48 inches OC and secured to alternating joists with No. 8 x 2½ inch coarse drywall screw through the center grommet. Furring channels are friction fitted into clips. Adjoining channels are overlapped as described in Item a. As an alternate, ends of adjoining channels may be overlapped 6 inches and secured together with two self-tapping No. 6 framing screws, min 7/16 inch long at the midpoint of the overlap, with one screw on each flange of the channel. Additional clips required to that supports the gypsum board butt joints, as described in Item 5.

**PAC INTERNATIONAL INC**—Type RSIC-1

4. **Gypsum Board**—Two layers of 1/2-inch-thick-by-4-feet-wide gypsum board installed perpendicular to resilient channels. Base layer of secured to resilient channels with 1 inch long Type S bugle head screws spaced 8 inches OC at the butted end joints and 16 inches OC in the field of the board. Face layer secured to resilient channels with 15/8 inch Type S bugle head screws spaced 8 inches OC in the field of the board and with 1½ inch long Type G screws spaced 8 inches OC at the butt joints located midspan between resilient channels. When **Steel Framing Members** (Item 3A) are used, gypsum board installed with long dimension parallel with trusses. Base layer attached to the furring channels using 1 inch long Type S bugle head steel screws spaced 12 inches OC in the field of the board. Butted end joints shall be staggered min 2 feet within the assembly, and occur midway between the continuous furring channels. At butted end joints, each end of each gypsum board shall be supported by a single length of furring channel equal to the width of the gypsum board plus 6 inches on each end. The two furring channels shall be spaced approximately 3½ inches OC, and be attached to underside of the joist with one RSIC-1 clip at each end of the channel. Screw spacing along the end joint shall be 8 inches OC. Butted base layer end joints to be offset a min of 24 inches in adjacent courses. Outer layer attached to the furring channels using 15/8 inch long Type S bugle-head steel screws spaced 8 inches OC at butted joints and 12 inches OC in the field. Butted end joints to be offset a min of 8 inches from base layer end joints. Butted side joints of outer layer to be offset min 18 inches from butted side joints of base layer.

**UNITED STATES GYPSUM CO**—Type C

\*Bearing the UL Classification Mark

**FIGURE 2**  
UL Design No. V448  
Nonbearing Wall Rating—1 HR.

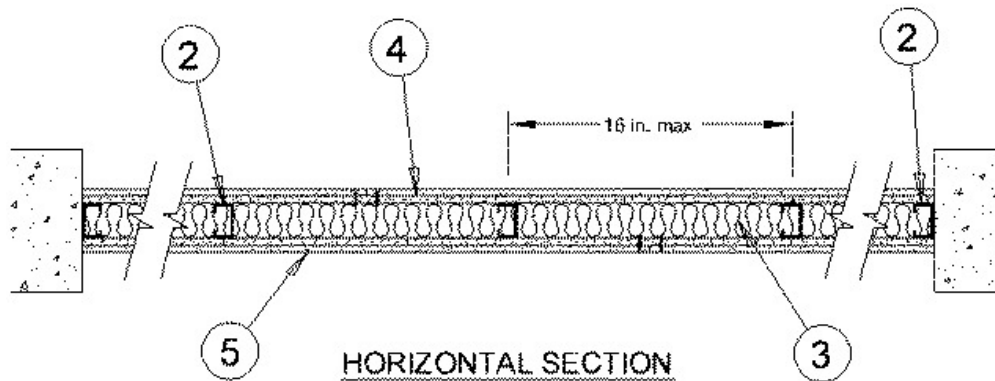

1. **Floor and Ceiling Runner**—(Not Shown)—Channel shaped, attached to floor and ceiling with steel fasteners spaced max 36 inches OC. Fabricated from min No. 25 MSG galv steel,  $3\frac{5}{8}$  inch deep and min  $1\frac{1}{4}$  inch wide.
2. **Steel Studs**—Channel shaped, spaced a max 16 inches OC. Fabricated from min 25 MSG galv steel, min  $3\frac{5}{8}$  inch wide by  $1\frac{1}{4}$  inch deep with  $\frac{1}{4}$  inch folded back return flange legs. Studs to be cut  $\frac{3}{8}$  inch less the assembly height. Steel studs friction-fitted into ceiling runners (Item 1). Studs attached to floor runners with  $\frac{7}{16}$  inch long Type S-12 pan-head, self-drilling, self-tapping steel screws on both sides of the studs or by welded or bolted connections designed in accordance with the AISI specifications. Where required for lateral support of studs, support shall be provided by means of steel straps, channels or other similar means as specified in the design of a particular steel stud wall system.
3. **Batts and blankets**—Nom 3-inch-thick, minimum 3.4 pcf mineral wool batts, friction fit between the studs and floor and ceiling runners.
4. **Mineral and Fiber Board\***—Nom  $\frac{1}{2}$ -inch-thick, 4-foot-wide Homasote Type 440-32 Sheathing. Installed with long dimension parallel with studs. Vertical joints centered on studs, and staggered one stud space from opposite side. Attached to studs with Type S-6  $1\frac{5}{8}$  inch long drywall screws, spaced 12 inches OC along interior studs at perimeter of panels.  
**HOMASOTE CO**—Homasote Type 440-32
5. **Gypsum Board\***— $\frac{5}{8}$ -inch-thick, 4-foot-wide. One layer of wallboard applied vertically over the mineral and fiber board with joints centered between studs and staggered min 16 inches on opposite sides, secured with Type S-10,  $1\frac{1}{2}$  inch long screws spaced 12 inches OC along the perimeter and 16 inches OC in the field.  
**CANADIAN GYPSUM COMPANY**—Types C, IP-X2.  
**UNITED STATES GYPSUM CO**—Types C, IP-X2.  
**USG MEXICO S A DE C V**—Types C, IP-X2.
6. **Joint Tape and Compound**—(Not Shown)—Outer layer joints covered with joint compound and paper or mesh tape. Screw heads covered with joint compound.

\*Bearing the UL Classification Mark