

## system No. HW-D-0034

September 01, 2016

<b>ANSI/UL2079</b>	<b>CAN/ULC S115</b>
Assembly Ratings — 1 and 2 Hr (See Item 2)	F Ratings — 1 and 2 Hr (See Item 2)
Nominal Joint Width — 1 In.	FT Ratings — 1 and 2 Hr (See Item 2)
Class II Movement Capabilities — 7% or 25% Compression or Extension (See Items 1C, 1A-D)	FH Ratings — 1 and 2 Hr (See Item 2)
L Rating At Ambient — Less Than 1 CFM/sq ft	FTH Ratings — 1 and 2 Hr (See Item 2)
L Rating At 400 F — Less Than 1 CFM/sq ft	Nominal Joint Width — 1 In.
	Class II Movement Capabilities — 7% or 25% Compression or Extension (See Items 1C, 1A-D)
	L Rating At Ambient — Less Than 1 CFM/sq ft
	L Rating At 400 F — Less Than 1 CFM/sq ft

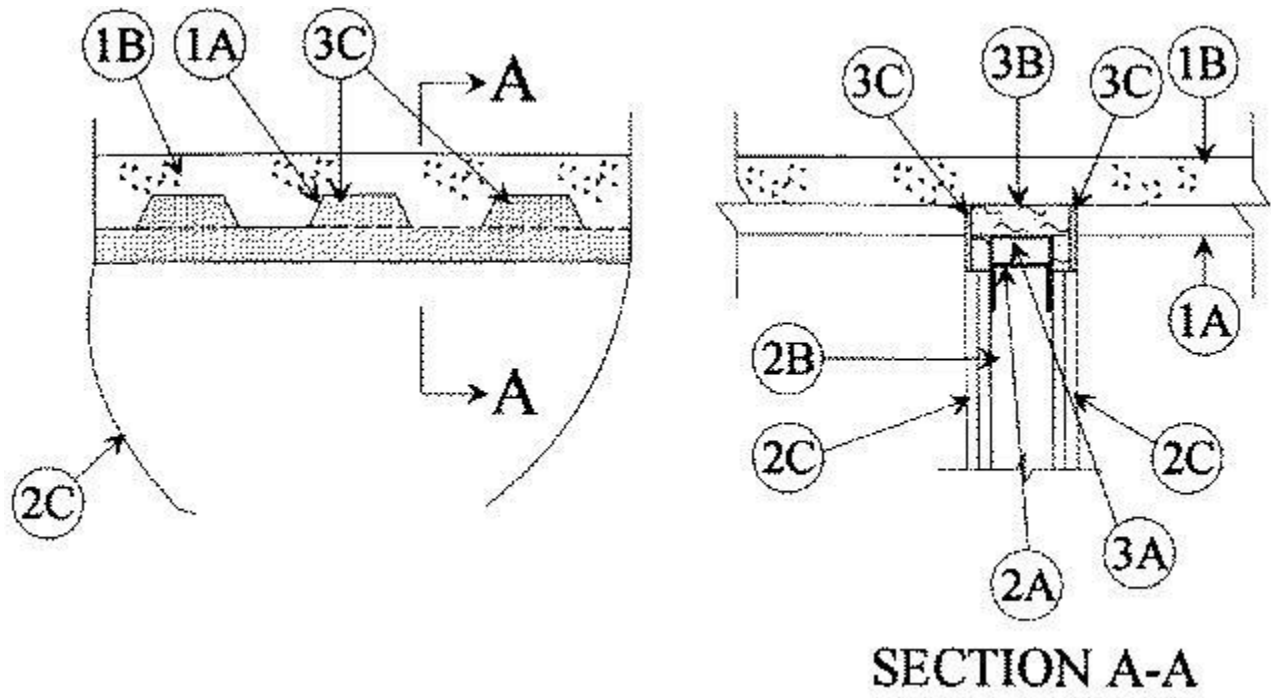

1. **Floor Assembly** — The fire-rated fluted steel deck/concrete floor assembly shall be constructed of the materials and in the manner described in the individual Floor-Ceiling Design in the UL Fire Resistance Directory and shall include the following construction features:

A. **Steel Floor And Form Units\*** — Max 3 in. (76 mm) deep galv steel fluted floor units.

B. **Concrete** — Min 2-1/2 in. (64 mm) thick reinforced concrete, as measured from the top plane of the floor units.

C. **Spray-Applied Fire Resistive Material\*** — (Optional, Not Shown) — After installation of the ceiling runner (Item 2A) or deflection channel (Item 3A), steel floor units to be sprayed with a min 5/16 in. (8 mm) to max 11/16 in. (17 mm) thickness of material in accordance with the specifications in the individual D700 or D800 Series Design. When spray applied fire resistive material is used, ceiling runner or deflection channel to be provided with 2 in. (51 mm) flanges. Excess material to be scraped from flanges of ceiling runner or deflection channel prior to installation of gypsum board. **When Spray-Applied Fire Resistance Material is used, Class II Movement Capabilities restricted to COMPRESSION ONLY.**

**ISOLATEK INTERNATIONAL** — Type 300

**GCP APPLIED TECHNOLOGIES INC — MK-6/HY**

1A. **Roof Assembly** — (Not Shown) — As an alternate to the floor assembly (Item 1), a fire rated fluted steel deck roof assembly may be used. The roof assembly shall be constructed of the materials and in the manner described in the individual P700, P800 or P900 Series Roof-Ceiling Design in the UL Fire Resistance Directory. The hourly fire rating of the roof assembly shall be equal to or greater than the hourly fire rating of the wall assembly. The roof assembly shall include the following construction features:

A. **Steel Roof Deck** — Max 3 in. (76 mm) deep galv steel fluted roof deck.

B. **Roof Insulation** — Min 2-1/4 in. (57 mm) thick poured insulating concrete, as measured from the top plane of the steel roof deck.

C. **Roof Covering\*** — Hot-mopped or cold-application materials compatible with insulating concrete.

D. **Spray-Applied Fire Resistive Material\*** — (Optional, Not Shown) — After installation of the ceiling runner (Item 2A) or deflection channel (Item 3A), steel floor units to be sprayed with a min 5/16 in. (8 mm) to max 11/16 in. (17 mm) thickness of material in accordance with the specifications in the individual P700 or P800 Series Design. When spray applied fire resistive material is used, ceiling runner or deflection channel to be provided with 2 in. (51 mm) flanges. Excess material to be scraped from flanges of ceiling runner or deflection channel prior to installation of gypsum board. **When Spray-Applied Fire Resistance Material is used, Class II Movement Capabilities restricted to COMPRESSION ONLY.**

**GCP APPLIED TECHNOLOGIES INC — MK-6/HY**

**ISOLATEK INTERNATIONAL — Type 300**

1B. **Floor Assembly** — (Not Shown) — As an alternate to the floor assembly (Item 1), min 4-1/2 in. (114 mm) thick structural concrete (100-150 pcf or 1600-2400 kg/m<sup>3</sup>) or min 6 in. (152 mm) thick hollow-core **Precast Concrete Units\***.

See **Precast Concrete Units** (CFTV) category in Fire Resistance Directory for names of manufacturers.

2. **Wall Assembly** — The 1 or 2 hr fire rated gypsum board/stud wall assembly shall be constructed of the materials and in the manner described in the individual U400 or V400 Series Wall and Partition Design in the UL Fire Resistance Directory and shall include the following construction features:

A. **Steel Floor and Ceiling Runners** — Floor and ceiling runners of wall assembly shall consist of galv steel channels sized to accommodate steel studs. Ceiling runner to be provided with min 1-1/4 in. (32 mm) to max 2 in. (51 mm) flanges. When deflection channel (Item 3A) is used, flange height of ceiling runner is to be equal to or greater than flange height of deflection channel and the ceiling runner is to nest within the deflection channel with a 1/2 to 3/4 in. (13 to 19 mm) gap maintained between the top of the ceiling runner and the top of the deflection channel. When deflection channel is not used, ceiling runner to be provided with min. 1-1/2 in. (38 mm) flanges. Ceiling runner installed perpendicular to direction of fluted steel deck and secured to valleys with steel masonry anchors or welds spaced max 24 in. (610 mm) OC.

A1. **Light Gauge Framing\* - —Slotted Ceiling Runner** — As an alternate to the ceiling runner in Item 2A, ceiling runner to consist of galv steel channel with slotted flanges sized to accommodate steel studs (Items 2B). Ceiling runner installed perpendicular to direction of fluted steel deck and secured to valleys with steel masonry anchors spaced max 24 in. (610 mm) OC. When slotted ceiling runner is used, deflection channel (Item 3A) shall not be used.

**BRADY CONSTRUCTION INNOVATIONS INC, DBA SLIPTRACK SYSTEMS** — SLP-TRK

**CALIFORNIA EXPANDED METAL PRODUCTS CO** — CST

**CLARKDIETRICH BUILDING SYSTEMS** — Type SLT, SLT-H

**MARINO/WARE, DIV OF WARE INDUSTRIES INC** — Type SLT

**QUAIL RUN BUILDING MATERIALS INC** — Slotted Deflection Track

**RAM SALES L L C** — RAM Slotted Track

**SCAFCO STEEL STUD MANUFACTURING CO**

**STEELER INC** — Steeler Slotted Ceiling Runner

**TELLING INDUSTRIES L L C** — True-Action Deflection Track

A2. **Light Gauge Framing — Floor and Ceiling Runners** — As an alternate to the ceiling and floor runners in Item 2A, 2A1 and 2A2, floor and ceiling runners to consist of galv steel channel sized to accommodate the **Light Gauge Framing\*** Slotted Stud (Item 2B1) or **Light Gauge Framing\*** Slider C-Clip System (Item 2B2). Floor and ceiling runners to be provided with min 1-1/4 in. and 3 in. (32 and 76 mm) flanges, respectively. Ceiling runner installed perpendicular to direction of fluted steel deck and secured to valleys with steel masonry anchors spaced max 12 in. (305 mm) OC. When ceiling runner is used, deflection channel (Item 3A) shall not be used.

**STEELER INC** — Floor and Ceiling Runners

A3. **Light Gauge Framing\* — Notched Ceiling Runner** — As an alternate to the ceiling runners in Items 2A through 2A3, notched ceiling runners to consist of C-shaped galv steel channel with notched return flanges sized to accommodate steel studs (Item 2B). Notched ceiling runner installed perpendicular to direction of fluted steel deck and secured to valleys with steel masonry anchors spaced max 24 in. (610 mm) OC. When notched ceiling runner is used, deflection channel (Item 3A) shall not be used.

**OLMAR SUPPLY INC** — Type SCR

A4. **Steel Framing Members\* — Sound Isolation Clips** — (Not Shown) — As an alternate attachment means for the ceiling runner to the bottom of the floor or roof assembly when no deflection channel (Item 3A) is used, sound isolation clips installed in accordance with the accompanying installation instructions. Sound isolation clip installed through nom 1 in. (25 mm) diam hole in ceiling runner and attached to top of ceiling runner using four min No. 8 by 1/2 in. (13 mm) long self-tapping galv steel screws. Sound isolation clips to be installed adjacent to every stud location but not more than 24 in. (610 mm) OC and attached to the underside of floor or roof assembly using min 3/16 in. (5 mm) diam by 2-1/2 in. (64 mm) long steel masonry anchors.

**PAC INTERNATIONAL L L C** — Type RSIC-U-HD

B. **Studs** — Steel studs to be min 3-1/2 in (89 mm) wide. Studs cut 1/2 to 3/4 in. (13 to 19 mm) less in length than assembly height with bottom nesting in and secured to floor runner. When deflection channel (Item 3A) is used, steel studs attached to ceiling runner with sheet metal screws located 1/2 in. (13 mm) below the bottom to the deflection channel. When deflection channel is not used, studs to nest in ceiling runner without attachment. When slotted ceiling runner (Item 2A2) is used, steel studs secured to slotted ceiling runner with No. 8 by 1/2 in. (13 mm) long wafer head steel screws at midheight of slot on each side of wall. Stud spacing not to exceed 24 in. (610 mm) OC.

B1. **Light Gauge Framing\* — Slotted Studs** — Slotted steel stud to be used in conjunction with **Light Gauge Framing\* — Floor and Ceiling Runners** (Item 2A3). Slotted steel studs to be min 3-1/2 in. (89 mm) wide. Slotted steel studs cut 1 in. (25 mm) less in length than assembly height with bottom nesting in and secured to both ceiling and floor runners. Ceiling runner secured to preformed slot within steel stud by means of No. 10 by 3/4 in. (19 mm) long low profile head steel screw. Floor runner attached to bottom of steel stud by means of No. 8 by 1/2 in. (13 mm) long pan head steel screw. Slotted steel stud spacing not to exceed 24 in. (610 mm) OC.

**STEELER INC** — Slotted Stud

**B2. Light Gauge Framing\* — Slider C-Clip System** — As an alternate to the **Light Gauge Framing\* — Slotted Steel Studs** (Item 2B1), a Slider C-Clip System consisting of a C shaped steel clip with a slotted opening and a steel stud to be used in conjunction with **Light Gauge Framing — Floor and Ceiling Runners** (Item 2A3). Steel clips and studs to be min 3-1/2 in. (89 mm) wide. Steel clip inserted into inside flange of steel stud without attachment. Total length of steel stud cut 1 in. (25 mm) less than assembly height with bottom of steel stud nesting in and secured to floor runner. Floor runner attached to bottom of steel stud by means of No. 8 by 1/2 in. (13 mm) long pan head steel screw. Ceiling runner secured to steel C-Clip by means of No. 10 by 3/4 in. (19 mm) long pan head steel screw located 3/8 in. (10 mm) below top of ceiling runner. Top row of gypsum board screws shall be centered within the preformed slot of the C-Clip. Steel stud and steel clips spacing not to exceed 24 in. (610 mm) OC.

**STEELER INC** — Slider C Clip System

**C. Gypsum Board\*** — Gypsum board sheets installed to a min total thickness of 5/8 in. or 1-1/4 in. (16 or 32 mm) on each side of wall for 1 hr or 2 hr fire rated wall, respectively. Wall to be constructed in the individual U400 or V400 Series Design in the UL Fire Resistance Directory, except that a nom 1 in. (25 mm) gap shall be maintained between the top of the wallboard and the bottom surface of the steel floor or roof deck. The screws attaching the gypsum board to the studs along the top of the wall shall be located 1 in. (25 mm) below the bottom of the ceiling runner. No gypsum board attachment screws shall be driven into the ceiling runner or into the optional deflection channel

**The hourly fire rating of the joint system is dependent upon the hourly fire rating of the wall assembly in which it is installed.**

**2A. Through Penetrant** — (Optional, Not Shown) — Nom 3/8 in. or 1/2 in. (10 or 13 mm) diam rigid steel conduit, steel electrical metallic tubing (EMT) or 1-1/2 in. (38 mm) Sch 40 PVC conduit may be installed within the flutes of the steel floor or roof deck. The conduit or EMT shall be located near the middepth of the steel deck with a clearance of 1/2 to 1-1/2 in. (13 to 38 mm) between the conduit or EMT and the steel deck. A max of one conduit or EMT is permitted in an individual flute. **When conduit or EMT is installed in flute of steel deck, the hourly rating of the joint system is 1 hr.**

**3. Joint System** — **Max separation between bottom of floor or roof deck and top of wall (at time of installation of joint system) is 1 in. (25 mm). The joint system is designed to accommodate a max 7% (for SpecSeal LC150 Sealant) or 25 % (for**

**SpecSeal ES Sealant) compression or extension from its installed width.** The joint system shall consist of forming and fill materials, with or without a deflection channel (Item 3A), as follows:

A. **Deflection Channel** — (Optional) — Max 2 in. (51 mm) deep min 24 gauge galv steel channel sized to accommodate ceiling runner (Item 2A). Deflection channel installed perpendicular to direction of fluted steel deck and secured to valleys of with steel masonry anchors or welds spaced max 24 in. (610 mm) OC. The ceiling runner (Item 2A) is installed within the deflection channel to maintain a 1/2 to 3/4 in. (13 to 19 mm) gap between the top of the ceiling runner and the top of the deflection channel. The ceiling runner nests inside the deflection channel without attachment.

B. **Forming Material\*** — Min 4-1/4 in. or 5-5/8 in. (108 or 149 mm) depth, for 1 hr or 2 hr fire rated wall, respectively, of 4 pcf (64 kg/m<sup>3</sup>) mineral wool batt insulation cut to the shape of the fluted deck, approx 20 percent larger than the area of the flutes and compressed into the flutes of the steel floor or roof deck between the top of the deflection channel and the steel floor or roof deck. When sound isolation clips (Item 2A5) are used, the space between the top of the ceiling runner and the underside of the floor or roof shall be tightly packed with mineral wool batt insulation. Additional 2 in. (51 mm) thick by 1 in. (25 mm) wide sections of mineral wool batt insulation are compressed 50 percent and installed cut edge first to fill the 1 in. (25 mm) gap between the top of the wall and bottom of the steel floor or roof deck. The forming material shall be recessed from each surface of wall to accommodate the required thickness of fill material (Item 3C).

**ROCK WOOL MANUFACTURING CO** — Delta Safing

**ROCKWOOL MALAYSIA SDN BHD** — Safe

**ROCKWOOL** — Safe

**THERMAFIBER INC** — Type SAF



**B1. Forming Material\*** — (Optional, Not Shown) — Preformed mineral wool plugs, formed to the shape of the fluted floor units, friction fit to completely fill the flutes above the ceiling channel. The plugs shall project beyond each side of the ceiling runner and shall be recessed from both wall surfaces to accommodate the required thickness of fill material (Item 3C). Additional forming material, described in Item 3B, to be used in conjunction with the plugs to fill the gap between the top of gypsum board and bottom of steel deck.

**THERMAFIBER INC** — TopStop mineral wool deck plugs Type SAF batts

**C. Fill, Void or Cavity Material\* — Sealant** — Min 1/4 in. (6 mm) thickness of fill material installed on each side of the wall in the flutes of the steel floor or roof deck and between the top of the wall and the bottom of the steel floor or roof deck, flush with each surface of wall.

**SPECIFIED TECHNOLOGIES INC** — SpecSeal ES Sealant, SpecSeal LC150 Sealant

**\* Indicates such products shall bear the UL or cUL Certification Mark for jurisdictions employing the UL or cUL Certification (such as Canada), respectively.**

[Last Updated](#) on 2016-09-01