

# Design No. V489

June 03, 2020

## Nonbearing Wall Ratings - 1, 2, 3 or 4 Hr (See Items 4 & 5)

\* Indicates such products shall bear the UL or cUL Certification Mark for jurisdictions employing the UL or cUL Certification (such as Canada), respectively.

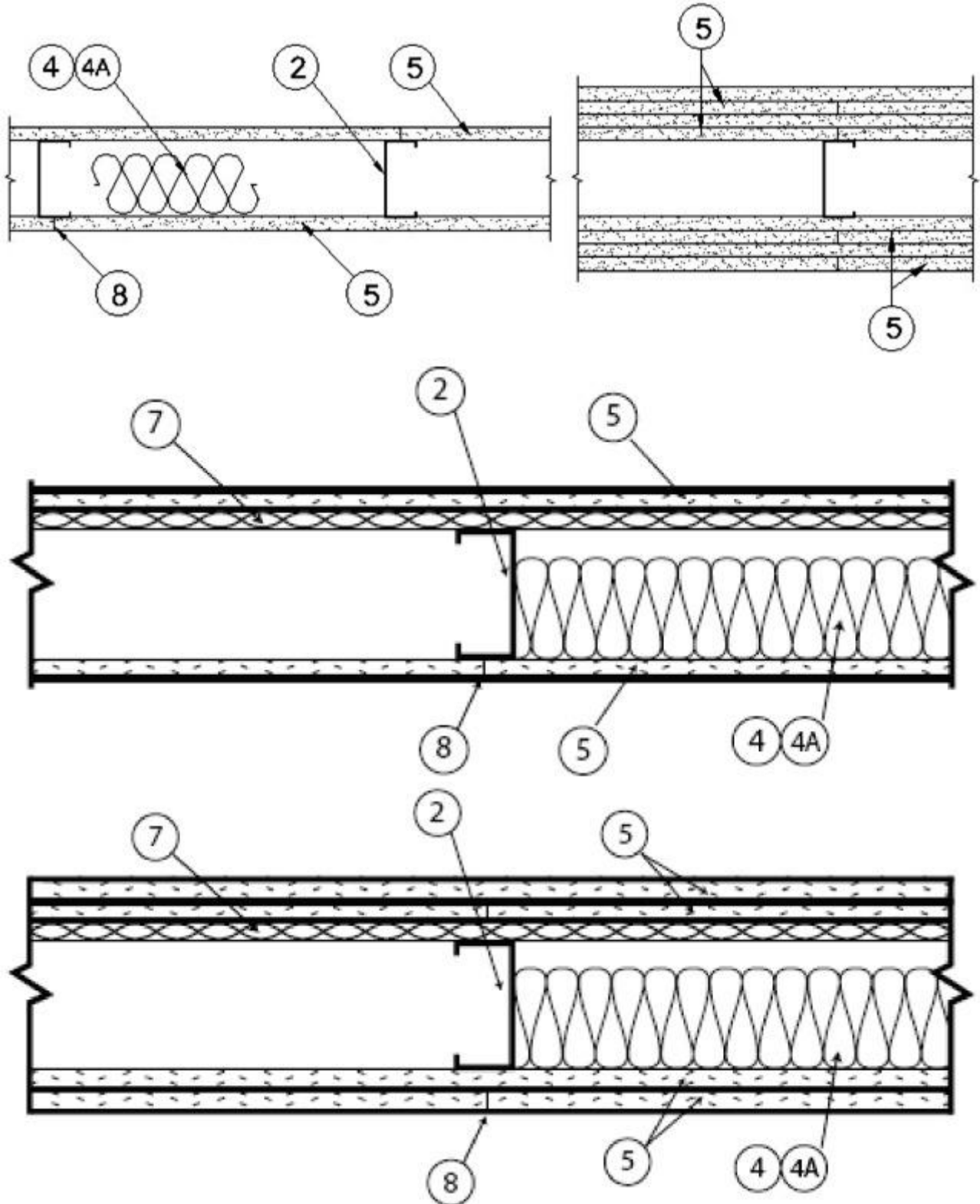

1. **Floor and Ceiling Runners** — (Not Shown) — Channel shaped, fabricated from min 25 MSG (0.018 in. min. bare metal thickness) corrosion-protected steel, min width to accommodate stud size, with min 1-1/4 in. long legs, attached to floor and ceiling with fasteners 24 in. OC max.

**1A. Floor and Ceiling Runners** — (Not Shown) — For use with Item 2A- Channel shaped, fabricated from min 20 MSG corrosion-protected or galv steel, min width to accommodate stud size, with min 1 in. long legs, attached to floor and ceiling with fasteners spaced max 24 in. OC.

**1B. Framing Members\* — Floor and Ceiling Runner** — Not Shown — In lieu of Item 1 — For use with Item 2B, proprietary channel shaped runners, min width to accommodate stud size, attached to floor and ceiling with fasteners 24 in. OC max.

**CALIFORNIA EXPANDED METAL PRODUCTS CO** — Viper20™ Track, Viper25™ Track

**CALIFORNIA EXPANDED METAL PRODUCTS CO** — Viper X Track

**CLARKDIETRICH BUILDING SYSTEMS** — CD ProTRAK

**CRACO MFG INC** — SmartTrack20™, SmartTrack25™

**DMFCWBS L L C** — ProTRAK

**MARINO/WARE, DIV OF WARE INDUSTRIES INC** — Viper20™ Track, Viper25™ Track, Viper20™ Track VT100

**FUSION BUILDING PRODUCTS** — Viper20™ Track, Viper25™ Track, Viper20™ Track VT100

**IMPERIAL MANUFACTURING GROUP INC** — Viper20™ Track, Viper25™ Track, Viper20™ Track VT100

**SCAFCO STEEL STUD MANUFACTURING CO** — Type SUPREME D24/30EQD and Type SUPREME D20

**RESCUE METAL FRAMING, L L C** — AlphaTRAK

**STUDCO BUILDING SYSTEMS** — CROCSTUD Track

**SUPER STUD BUILDING PRODUCTS** — The Edge

**TELLING INDUSTRIES L L C** — TRUE-STUD™, Viper20™, Viper25™ Track

2. **Steel Studs** — Channel shaped, fabricated from min 25 MSG (0.018 in. min. bare metal thickness) corrosion-protected steel, min width as indicated under Item 5, min 1-1/4 in. flanges and 1/4 in. return, spaced a max of 24 in. OC. Studs to be cut 3/8 to 3/4 in. less than assembly height.

2A. **Steel Studs** — (As an alternate to Item 2, For use with Items 5A and 10) — Channel shaped, fabricated from min 20 MSG corrosion-protected or galv steel, 3-1/2 in. min width, min 1-1/2 in. flanges and 1/4 in. return, spaced a max of 16 in. OC. Studs friction-fit into floor and ceiling runners. Studs to be cut 5/8 to 3/4 in. less than assembly height.

2B. **Framing Members\*** — **Steel Studs** — (As an alternate to Item 2) — Proprietary channel shaped studs, 3-5/8 in. deep spaced a max of 24 in. OC. Studs to be cut 3/4 in less than the assembly height. For direct attachment of gypsum board only.

**CALIFORNIA EXPANDED METAL PRODUCTS CO** — Viper20™, Viper25™

**CLARKDIETRICH BUILDING SYSTEMS** — CD ProTRAK

**CRACO MFG INC** — SmartStud20™, SmartStud25™

**DMFCWBS L L C** — ProSTUD

**MARINO/WARE, DIV OF WARE INDUSTRIES INC** — Viper20™, Viper25™

**FUSION BUILDING PRODUCTS** — Viper20™, Viper25™

**IMPERIAL MANUFACTURING GROUP INC** — Viper20™, Viper25™

**SCAFCO STEEL STUD MANUFACTURING CO** — Type SUPREME D24/30EQD and Type SUPREME D20

**RESCUE METAL FRAMING, L L C** — AlphaSTUD

**STUDCO BUILDING SYSTEMS** — CROCSTUD

**SUPER STUD BUILDING PRODUCTS** — The Edge

**TELLING INDUSTRIES L L C** — TRUE-STUD™, Viper20™, Viper25™

3. **Wood Structural Panel Sheathing** — (Optional Item, Not Shown — For use on the base of the Rated Systems in addition to the required gypsum layers) — 4 ft wide, 7/16 in. thick oriented strand board (OSB) or 15/32 in. thick structural 1 sheathing (plywood) complying with DOC PS1 or PS2, or APA Standard PRP-108, manufactured with exterior glue, applied horizontally or vertically to the steel studs. Vertical joints centered on studs, and staggered one stud space from wallboard joints. Attached to studs with flat-head self-drilling tapping screws with a min. head diam. of 0.292 in. at maximum 6 in. OC. in the perimeter and 12 in. OC. in the field. When used, gypsum panels attached over OSB or plywood panels and fastener lengths for gypsum panels described in Item 6 must be increased by min. 1/2 in.

4. **Batts and Blankets\*** — (Required as indicated under Item 5) — Mineral wool batts, friction fitted between studs and runners. Min nom thickness as indicated in the table under Item 5.

See **Batts and Blankets (BKNV or BZJZ) Categories** for names of Classified companies.

4A. **Batts and Blankets\*** — (Required as indicated under Item 5) — Placed in stud cavities, any glass fiber or mineral wool insulation bearing the UL Classification Marking as to Surface Burning Characteristics and/or Fire Resistance having a minimum density of 0.5 pcf.

See **Batts and Blankets (BKNV or BZJZ) Categories** for names of Classified companies.

4B. **Batts and Blankets\*** — (Optional) — Placed in stud cavities, any glass fiber or mineral wool insulation bearing the UL Classification Marking as to Surface Burning Characteristics and/or Fire Resistance.

See **Batts and Blankets (BKNV or BZJZ) Categories** for names of Classified companies.

5. **Gypsum Board\*** — Gypsum panels 4 ft. wide with beveled, square or tapered edges. Vertical or horizontal application methods as described under Item 6. The thickness and number of layers for the 1 hr, 2 hr, 3 hr and 4 hr ratings are as follows:

### Gypsum Board Protection on each Side of Wall

System No.	Rating, Hr	Min Stud Depth, Item 2, In.	Min Stud Depth, Item 2B, In.	No. of Layers & Thks of Panel	For Use With Items 2 or 2A, Min Thks of Insulation (Item 4)	For Use With Item 2B, Min Thks of Insulation (Item 4A)
A	1	3-5/8	3-5/8	1 layer, 5/8 in. thick	Optional (*)	3-1/2 in. thick
B	1	2-1/2	3-5/8	1 layer, 1/2 in. thick	1-1/2 in. thick	1-1/2 in. thick
C	2	1-5/8	3-5/8	2 layers, 1/2 in. thick	Optional	Optional
D	2	1-5/8	3-5/8	2 layers, 5/8 in. thick	Optional	Optional
E	3	1-5/8	3-5/8	3 layers, 1/2 in. thick	Optional	Optional
F	3	1-5/8	3-5/8	3 layers, 5/8 in. thick	Optional	Optional
G	4	1-5/8	3-5/8	4 layers, 1/2 in. thick	Optional	Optional
H	4	1-5/8	3-5/8	4 layers, 5/8 in. thick	Optional	Optional

\* Note System A, when applied horizontally to Item 2, insulation, Item 4A, must be used.

**AMERICAN GYPSUM CO** — 1/2 in. thick Type AG-C; 5/8 in. thick Types AGX-1, M-Glass, AG-C, LightRoc

**GEORGIA-PACIFIC GYPSUM L L C** — 1/2 in. and 5/8 in. Type TG-C

5A. **Gypsum Board\*** — (As an alternate to Item 5 when used as the base layer on one or both sides of wall, For direct attachment only, not to be used with Item 3) — Nom 5/8 in. thick lead backed gypsum panels with beveled, square or tapered edges, applied vertically. Vertical joints centered over studs and staggered min 1 stud cavity on opposite sides of studs. Gypsum board secured to studs with 1-1/4 in. long Type S-12 steel screws spaced 8 in. OC at perimeter and 12 in. OC in the field. For use with steel studs Item 2B only.

**RAY-BAR ENGINEERING CORP** — Type RB-LBG

6. **Fasteners** — (Not Shown) — For use with Item 5. Type S or S-12, unless otherwise noted, used to attach gypsum boards to steel studs and tracks. All vertical joints of gypsum boards centered over studs.

## System A

**For Steel Studs, Items 2 or 2A** — Joints oriented vertically and staggered on opposite sides of the assembly. Attached to steel studs and floor and ceiling track with 1 in. long steel screws spaced 8 in. OC. along edges of board and 12 in. OC in the field of the board.

**For Steel Studs, Items 2 or 2B** — Joints oriented vertically or horizontally. Vertical joints staggered on opposite sides of the assembly. **For Horizontal Application** (American Gypsum Company's 5/8 in. thick Types AGX-1, M-Glass or AG-C only) — Attached to studs with 1 in. long steel screws spaced 8 in OC along the studs and 12 in. OC along the floor and ceiling runners. Horizontal joints staggered min 12 in. on opposite faces. Horizontal joints do not need to be backed by steel framing. **For Vertical Application** — Attached to studs with 1 in. long steel screws spaced 8 in. OC at the perimeter, starting 4 in. from the edge of the boards, and 12 in. OC in the field of the boards, starting 6 in. from the edge of the board.

## System B

**For Steel Studs, Items 2, 2A and 2B** — Joints oriented vertically or horizontally. Vertical joints staggered on opposite sides of the assembly. **For Horizontal Application** — Attached to studs with 1 in. long steel screws spaced 8 in OC along the vertical joints and 12 in. OC in the field with the first and last screws installed 1-1/2 in. from board edges. Gypsum panels secured to the floor and ceiling runners with 1 in. long steel screws spaced 16 in. OC with the first and last screws installed 1-1/2 in. from board edges. Horizontal joints need not be staggered on opposite faces or backed by steel framing. **For Vertical Application** — Attached to studs with 1 in. long steel screws spaced 8 in. OC at the perimeter and 12 in. OC in the field of the boards. Gypsum panels secured to the floor and ceiling runners with 1 in. long steel screws spaced 16 in. OC.

## System C

**For Steel Studs, Items 2 and 2A** — Joints oriented vertically or horizontally. Vertical joints staggered on opposite sides of the assembly and offset between layers. **For Vertical Application** — Inner layer attached to studs with 1 in. long steel screws spaced 24 in. O.C. in the field and along the vertical edges. Outer layer attached to the studs over the inner layer with 1-5/8 in. long steel screws spaced 12 in. O.C. in the field, along the vertical edges, and to the floor and ceiling runners. Joints outer layer offset from inner layer joints. **For Horizontal Application** — As described below for Steel Studs, Item 2B.

**For Steel Studs, Item 2B** — Joints oriented vertically or horizontally. Vertical joints staggered on opposite sides of the assembly and offset between layers. **For Horizontal Application** — Inner layer attached to studs with 1 in. long steel screws. Outer layer attached to studs with 1-5/8 in. long steel screws. Screws on inner layer spaced 16 in. OC along the studs with the first and last screws installed 1-1/2 in. from board edges. Screws on outer layer spaced 16 in. OC along the studs with the first and last screws installed 1-1/2 in. and 8 in. from board edges. Gypsum panels on each layer secured to the floor and ceiling runners with steel screws spaced 16 in. OC with the first and last screws installed 1-1/2 in. from board edges. Horizontal joints need not be staggered on opposite faces or backed by steel framing. Horizontal joints offset min. 12 in. between layers. **For Vertical Application** — Inner layer attached to studs with 1 in. long steel screw. Outer layer attached to studs with 1-5/8 in. long steel screws. Screws on each layer spaced 8 in. OC at the perimeter and 12 in. OC in the field of the boards. Gypsum panels on each layer secured to the floor and ceiling runners steel screws spaced 16 in. OC.

## System D

**For Steel Studs, Items 2 and 2A** — Joints oriented vertically or horizontally. Vertical joints staggered on opposite sides of the assembly. **For Vertical Application** — Inner layer attached to studs with 1 in. long steel screws spaced 16 in. OC in the field and along the vertical edges. Outer layer attached to the studs over the inner layer with 1-5/8 in. long steel screws spaced 16 in. OC in the field and along the vertical edges and 12 in. OC to the floor and ceiling runners. Joints outer layer offset from inner layer joints. **For Horizontal Application** — As described below for Steel Studs, Item 2B.

**For Steel Studs, Item 2B** — Joints oriented vertically or horizontally. Vertical joints staggered on opposite sides of the assembly. **For Horizontal Application** — Inner layer secured to the steel studs 1 in. long steel screws spaced 24 in. OC, and to the track only, spaced 24 in. OC. Outer layer secured to studs with 1-5/8 in. long screws spaced 16 in. OC, and to the track only, spaced 16 in. OC. Horizontal joints on the face layer are staggered 12 in. from the base layer. Horizontal joints not need be backed. **For Vertical Application** — Inner layer attached with 1 in. long steel screws spaced 12 in. OC along the top and bottom tracks with one screw located 6 in. from each edge of the board and 16 in. OC along the studs with one screw located 8 in. from one edge of the board. Outer layer attached with 1-5/8 in. steel screws spaced 12 in. OC along the top and bottom tracks with one screw located 1-1/2 in. from each edge of the board and 16 in. OC along the studs with one screw located 8 in. from one edge of the board as to offset the face layer screws 8 in. from the base layer screws. Vertical joints in adjacent layers staggered and on opposite sides of the wall.

## System E

**For Steel Studs, Items 2 and 2A** — Joints oriented vertically or horizontally. Vertical joints staggered on opposite sides of the assembly and offset between layers. **For Vertical Application** — Inner layers to be applied vertically with joints centered over studs. Outer layer may be applied vertically or horizontally. First layer fastened to each stud with 1 in. long steel screws. Second layer fastened to each stud through the first layer with 1-5/8 in. long steel screws. Third layer fastened to each stud through the first and second layers with 2-1/4 in. long self-tapping steel screws. First and second layer screws shall be located 4 and 3 in. from top and bottom of wall, respectively, with a maximum spacing of 48 in. OC vertically. The third layer screws shall be located 2 in. from top and bottom of wall with a maximum spacing of 12 in. OC vertically. Each third layer horizontal board end shall be centered over and secured to the stud with steel screws spaced 1/2 in. from end joint and 12 in. OC vertically. Third layer, also secured to the first and the second layers with 1-1/2 in. long, Type G, Self-tapping steel screws located midway between studs and 1 in. from the horizontal joint. Board end joints shall be staggered. Vertical board joints to be staggered from the joints in the adjacent layer and on opposite sides of studs. **For Horizontal Application** — As described below for Steel Studs, Item 2B.

**For Steel Studs, Item 2B** — Joints oriented vertically or horizontally. Vertical joints staggered on opposite sides of the assembly and offset between layers. **For Horizontal Application** — Inner layer attached to studs with 1 in. long steel screws. Middle layer attached to studs with 1-5/8 in. long steel screws. Outer layer secured to studs with 2-1/4 in. long steel screws. Screws on inner layers spaced 16 in. OC along the studs with the first and last screws installed 1-1/2 in. from board edges. Screws on outer layer spaced 16 in. OC along the studs with the first and last screws installed 1-1/2 in. and 8 in. from board edges. Horizontal joints need not be staggered on opposite faces or backed by steel framing. Horizontal joints offset min. 12 in. between layers. **For Vertical Application** — Inner layer attached to studs with 1 in. long steel screws. Middle layer attached to studs with 1-5/8 in. long steel screws. Outer layer attached to studs with 2-

1/4 in. long steel screws. Screws on each layer spaced 8 in. OC at the perimeter and 12 in. OC in the field of the boards. Gypsum panels on each layer secured to the floor and ceiling runners steel screws spaced 16 in. OC.

## System F

**For Steel Studs, Items 2, 2A and 2B** — Joints oriented vertically or horizontally. Vertical joints staggered on opposite sides of the assembly and offset between layers. **For Horizontal Application** — Inner layer secured to the steel studs 1 in. long steel screws spaced 24 in. OC, and to the track only, spaced 24 in. OC. Middle layer secured to studs with 1-5/8 in. long screws spaced 24 in. OC, and to the track only, spaced 24 in. OC. Outer layer secured to studs with 2-1/4 in. long screws spaced 16 in. OC, and to the track only, spaced 16 in. OC. Horizontal joints are staggered 12 in. between layers. Horizontal joints not need be backed. **For Vertical Application** — Inner layer attached with 1 in. long steel screws spaced 12 in. OC along the top and bottom tracks with one screw located 6 in. from each edge of the board and 16 in. OC along the studs. Middle layer attached with 1-5/8 in. long steel screws spaced 12 in. OC along the top and bottom tracks and 16 in. OC along the studs with one screw located 8 in. from one edge of the board as to offset the face layer screws 8 in. from the middle layer screws. Outer layer attached with 2-1/4 in. long steel screws spaced 12 in. OC along the top and bottom tracks with one screw located 6 in. from each edge of the board and 16 in. OC along the studs and offset 8 in. from the middle layer screws. Vertical joints in adjacent layers staggered and on opposite sides of the wall.

## System G

**For Steel Studs, Items 2 and 2A** — Joints oriented vertically or horizontally. Vertical joints staggered on opposite sides of the assembly and offset between layers. **For Vertical Application** — Inner layers to be applied vertically with joints centered over studs. Outer layer may be applied vertically or horizontally. First layer fastened to each stud with 1 in. long steel screws. Second layer fastened to each stud through the first layer with 1-5/8 in. long steel screws. Third layer fastened to each stud through the first and second layers with 2-1/4 in. long steel screws. Fourth layer fastened to each stud through the first, second and third layers with 2-5/8 in. long steel screws. First layer screws shall be located 5 in. from top and bottom of wall with a maximum spacing of 48 in. OC vertically between top and bottom screws. Second and third layer screws shall be located 4 and 3 in., respectively, from the top and bottom of wall with the same vertical spacing as the first layer screws. Fourth layer screws shall be located 2 in. from top and bottom of wall and spaced 12 in. OC vertically. Each fourth layer horizontal board end shall be centered over and secured to the stud with screws spaced 1/2 in. from end joint and 12 in. OC vertically. Board end joints shall be staggered. At board side joints all screws shall be located 1/2 in. from the joints. Fourth layer also secured to the second and third layers with 1-1/2 in. long, Type G steel screws located midway between studs and 1 in. from the horizontal joint. Joints in each layer of gypsum board to be staggered from the joints in the adjacent layer and on opposite sides of studs. **For Horizontal Application** — As described below for Steel Studs, Item 2B.

**For Steel Studs, Item 2B** — Joints oriented vertically or horizontally. Vertical joints staggered on opposite sides of the assembly and offset between layers. **For Horizontal Application** — Inner layer attached to studs with 1 in. long steel screws. Second layer attached to studs with 1-5/8 in. long steel screws. Third layer secured to studs with 2-1/4 in. long steel screws. Outer layer secured to steel studs with 2-5/8 in. long steel screws. Screws on inner layers spaced 16 in. OC along the studs with the first and last screws installed 1-1/2 in. from board edges. Screws on outer layer spaced 16 in. OC along the studs with the first and last screws installed 1-1/2 in. and 8 in. from board edges. Horizontal joints need not be staggered on opposite faces or backed by steel framing. Horizontal joints offset min.12 in. between layers. **For Vertical Application** — Inner layer attached to studs with 1 in. long steel screws. Second layer attached to studs with 1-5/8 in. long steel screws. Third layer attached to studs with 2-1/4 in. long steel screws. Outer layer secured to steel studs with 2-5/8 in. long steel screws. Screws on each layer spaced 8 in. OC at the perimeter and 12 in. OC in the field of the boards. Gypsum panels on each layer secured to the floor and ceiling runners steel screws spaced 16 in. OC.

## System H

**For Steel Studs, Items 2, 2A and 2B** — Joints oriented vertically or horizontally. Vertical joints staggered on opposite sides of the assembly. **For Horizontal Application** — Inner layer secured to the steel studs 1 in. long steel screws spaced 24 in. OC, and to the track only, spaced 24 in. OC. Second layer secured to studs with 1-5/8 in. long screws spaced 24 in. OC, and to the track only, spaced 24 in. OC. Third layer secured to studs with 2-5/8 in. long screws spaced 24 in. OC, and to the track only, spaced 24 in. OC. Outer layer secured to studs with 3 in. long screws spaced 16

in. OC, and to the track only, spaced 16 in. OC. Horizontal joints are staggered 12 in. between layers. Horizontal joints not need be backed. **For Vertical Application** — Inner layer attached with 1 in. long steel screws spaced 12 in. OC along the top and bottom tracks with one screw located 6 in. from each edge of the board and 16 in. OC along the studs. Second layer attached with 1-5/8 in. long steel screws spaced 12 in. OC along the top and bottom tracks with one screw located 1-1/2 in. from each edge of the board and 16 in. OC along the studs with one screw located 8 in. from one edge of the board as to offset the face layer screws 8 in. from the middle layer screws. Third layer attached with 2-5/8 in. long steel screws spaced 12 in. OC along the top and bottom tracks with one screw located 6 in. from each edge of the board and 16 in. OC along the studs and offset 8 in. from the middle layer screws. Vertical joints in adjacent layers staggered and on opposite sides of the wall. Outer layer attached with 3 in. long steel screws spaced 12 in. OC along the top and bottom tracks with one screw located 6 in. from each edge of the board and 16 in. OC along the studs and offset 8 in. from the middle layer screws. Vertical joints in adjacent layers staggered and on opposite sides of the wall.

**7. Furring Channels** — (Optional, for single or double layer system) — Resilient furring channels fabricated from min 25 MSG corrosion-protected steel, spaced a max of 24 in. OC. Flange portion attached to each intersecting stud with 1/2 in. long Type S-12 steel screws. Not for use with Item 5A.

**7A. Steel Framing Members\*** — (Not Shown) — Optional on one or both sides, not shown, for single or double layer systems — As an alternate to Item 7, furring channels and Steel Framing Members as described below. Not for use with Item 5A.

a. **Furring Channels** — Formed of No. 25 MSG galv steel. 2-9/16 in. or 2-23/32 in. wide by 7/8 in. deep, spaced max. 24 in. OC perpendicular to studs. Channels secured to studs as described in Item 7Ab. Gypsum board attached to furring channels as described in Item 6.

b. **Steel Framing Members\*** — Used to attach furring channels (Item 7Aa) to studs (Item 2 or 2A). Clips spaced max. 48 in. OC. RSIC-1 and RSIC-1 (2.75) clips secured to studs with No. 8 x 1-1/2 in. minimum self-drilling, S-12 steel screw through the center grommet. RSIC-V and RSIC-V (2.75) clips secured to studs with No. 8 x 9/16 in. minimum self-drilling, S-12 steel screw through the center hole. Furring channels are friction fitted into clips. RSIC-1 and RSIC-V clips for use with 2-9/16 in. wide furring channels. RSIC-1 (2.75) and RSIC-V (2.75) clips for use with 2-23/32 in. wide furring channels.

**PAC INTERNATIONAL L L C** — Types RSIC-1, RSIC-V, RSIC-1 (2.75), RSIC-V (2.75).

**7B. Steel Framing Members\*** — (Optional, Not Shown) — As an alternate to Item 7, for single or double layer systems, furring channels and Steel Framing Members on only one side of studs as described below. Not for use with Item 5A.

a. **Furring Channels** — Formed of No. 25 MSG galv steel, spaced 24 in. OC perpendicular to studs. Channels secured to studs as described in Item 7Bb. Batts and Blankets placed in stud cavity as described in Item 5. Two layers of gypsum board attached to furring channels as described in Item 6.

b. **Steel Framing Members\*** — Used to attach furring channels (Item 7Ba) to one side of studs (Item 2 or 2A) only. Clips spaced 48 in. OC., and secured to studs with two No. 8 x 2-1/2 in. coarse drywall screws, one through the hole at each end of the clip. Furring channels are friction fitted into clips.

**KINETICS NOISE CONTROL INC** — Type Isomax

**7C. Steel Framing Members\*** — (Optional, Not Shown) — As an alternate to Item 7, for single or double layer systems, furring channels and Steel Framing Members as described below. Not for use with Item 5A.

a. **Furring Channels** — Formed of No. 25 MSG galv steel. Spaced 24 in. OC perpendicular to studs. Channels secured to studs as described in Item b. Ends of adjoining channels overlapped 6 in. and tied together with double strand of No. 18 AWG galvanized steel wire. Gypsum board attached to furring channels as described in Item 6.



b. **Steel Framing Members\*** — Used to attach furring channels (Item 7Ca) to studs. Clips spaced 48 in. OC., and secured to studs with 2 in. coarse drywall screw with 1 in. diam washer through the center hole. Furring channels are friction fitted into clips.

**STUDCO BUILDING SYSTEMS** — RESILMOUNT Sound Isolation Clips - Type A237 or A237R

7D. **Steel Framing Members\*** — (Optional, Not Shown) — As an alternate to Item 7, for single or double layer systems, furring channels and Steel Framing Members as described below. Not for use with Item 5A.

a. **Furring Channels** — Formed of No. 25 MSG galv steel, spaced 24 in. OC, and perpendicular to studs. Channels secured to studs as described in Item b. Ends of adjoining channels overlapped 6 in. and secured in place with a double strand of No. 18 AWG twisted steel wire. Gypsum board attached to furring channels as described in Item 6.

b. **Steel Framing Members\*** — Used to attach furring channels (Item 7Da) to studs. Clips spaced 48 in. OC, and secured to studs with No. 8 x 2-1/2 in. coarse drywall screw through the center hole. Furring channels are friction fitted into clips.

**REGUPOL AMERICA** — Type SonusClip

7E. **Steel Framing Members\*** — (Optional, Not Shown) — As an alternate to Item 7, for single or double layer systems, resilient channels and Steel Framing Members as described below. Not for use with Item 5A.

a. **Resilient Channels** — Formed of No. 25 MSG galv steel, spaced 24 in. OC, and perpendicular to studs. Channels secured to studs as described in Item b. Ends of adjoining channels overlapped 6 in. and secured in place with two No. 8 15 x 1/2 in. Philips Modified Truss screws spaced 2-1/2 in. from the center of the overlap. Gypsum board attached to resilient channels as described in Item 6.

b. **Steel Framing Members\*** — Used to attach resilient channels (Item 7Ea) to studs. Clips spaced 48 in. OC., and secured to studs with No. 8 x 2-1/2 in. coarse drywall screw through the center hole. Resilient channels are secured to clips with one No. 10 x 1/2 in. pan-head self-drilling screw.

**KEENE BUILDING PRODUCTS CO INC** — Type RC+ Assurance Clip

8. **Joint Tape and Compound** — Vinyl or casein, dry or premixed joint compound applied in two coats to joints and screw heads of outer layers. Paper tape, nom 2 in. wide, embedded in first layer of compound over all joints of outer layer panels. Paper tape and joint compound may be omitted when gypsum panels are supplied with a square edge from American Gypsum Co.

9. **Cementitious Backer Units\*** — (Optional Item, Not Shown — For use on the face of the Rated Systems in addition to the required gypsum layers) — 7/16 in., 1/2 in., 5/8 in., 3/4 in. or 1 in. thick, min. 32 in. wide. Applied vertically or horizontally with vertical joints centered over studs. Fastened to studs and runners with cement board screws of adequate length to penetrate stud by a minimum of 3/8 in. for steel framing members spaced a max of 8 in. OC. When 4 ft. wide boards are used, horizontal joints need not be backed by framing.

**NATIONAL GYPSUM CO** — Type DuraBacker, PermaBase, DuraBacker Plus, or PermaBase Plus

10. **Cementitious Backer Units\*** — (Optional Item, Not Shown — For use on the face of the Rated Systems in addition to the required gypsum layers) — 1/2 in. or 5/8 in. thick, applied vertically or horizontally with vertical joints centered over studs. Fastened to studs and bottom runners max of 8 in. OC with the uppermost screws placed 1/2 in.

to 2 in below the bottom edge of the leg of the top runner, with corrosion resistant, chamfered, ribbed wafer head screws with a minimum head diameter of 0.400 inch. For use with steel studs Item 2A only.

**UNITED STATES GYPSUM CO** — Type DCB

11. **Siding, Brick or Stucco** — (Optional Item, Not Shown — For Use On Face Of Rated Systems With All Standard Items Required) - Aluminum, vinyl or steel siding, brick veneer or stucco, meeting the requirements of local code agencies, installed over gypsum panels. Brick veneer attached to studs with corrugated metal wall ties attached to each stud with steel screws, not more than each sixth course of brick.

12. **Lead Batten Strips** — (Not Shown, For Use With Item 5A) — Lead batten strips, min 1-1/2 in. wide, max 10 ft long with a max thickness of 0.125 in. Strips placed on the interior face of studs and attached from the exterior face of the stud with two 1 in. long Type S-12 pan head steel screws, one at the top of the strip and one at the bottom of the strip. Lead batten strips to have a purity of 99.9% meeting the Federal specification QQ-L-201f, Grade "C". Lead batten strips required behind vertical joints of lead backed gypsum wallboard (Item 5A) and optional at remaining stud locations.

13. **Lead Discs or Tabs** — (Not Shown, For Use With Item 5A) — Used in lieu of or in addition to the lead batten strips (Item 12) or optional at other locations - Max 3/4 in. diam by max 0.125 in. thick lead discs compression fitted or adhered over steel screw heads or max 1/2 in. by 1-1/4 in. by max 0.125 in. thick lead tabs placed on gypsum boards (Item 5A) underneath screw locations prior to the installation of the screws. Lead discs or tabs to have a purity of 99.9% meeting the Federal specification QQ-L-201f, Grade "C".

14. **Caulking and Sealants\*** — (Optional, Not Shown) — A bead of acoustical sealant applied around the partition perimeter for sound control. Caulking and Sealants to bear the Classification Mark of UL for Surface Burning Characteristics with a flame spread index of less than 200 and a smoke developed index less than 450.

**\* Indicates such products shall bear the UL or cUL Certification Mark for jurisdictions employing the UL or cUL Certification (such as Canada), respectively.**

[Last Updated](#) on 2020-06-03